



***IDRODEPUREX IMPIANTI* s.r.l.**

WATER TREATMENT – AIR CLEANING – FUMES AND DUST SUCTION – ALTERNATIVE ENERGY

AIR CLEANING

IDRODEPUREX IMPIANTI has a leading role in terms of planning regarding environment protection systems; our ARIA division's task is the planning, development, production and marketing of air filtering systems being particularly aimed at protecting and cleaning up the working environment. Industrial production processes often allow harmful substances to form: gas, mist, dust, vapour and toxic fumes are spread and conveyed through a vital element, the air and this causes a pollution of the working environment.

A polluted working environment can damage personnel's health, reduce productivity and create poor quality products. IDRODEPUREX IMPIANTI specializes in developing centralized fume plants being able to extract welding smoke, oil mist, dust, solvents and any other gaseous pollutant.

The planning of the plants is carried out by customizing the product according to customer's needs. The plant is produced within a short time; to produce the latter, high quality materials are utilized and the plant Dimensionsng is created according to the working environment safety rules (152/06 law decree).

Moreover, our structure specializes in developing welding smoke extraction plants on robotized islands with automatized, customized solutions and/or with trailer-mounted sliding ducts. IDRODEPUREX IMPIANTI is able to create technical solutions being suitable for any need (from mobile plants for only one user to big centralized plants). A lot of experience as well as a constantly innovative technology allows us to offer high quality products with the best quality/price ratio.

Plants & systems planned by IDRODEPUREX IMPIANTI allow to extract and filter:

- **smoke from welding, oxygene lance cutting, plasma cutting**
- **plastics hot forming smoke**
- **rubber pressing smoke**
- **foundry smoke**
- **oil mist and fumes from mechanical processes**
- **dust and chips from mechanical processes**
- **dust and chips from wood processing**
- **exhalations from plastics and composite materials**
- **dust from grinding and polishing**
- **dust from marble processing**
- **painting dust and vapour**
- **exhalations from industrial solvents**
- **exhalations from superficial metal treatments**
- **vapour and smell of cooking in catering**
- **exhausted gas from vehicles.**

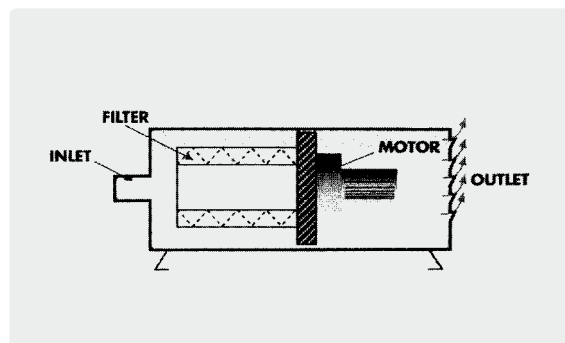
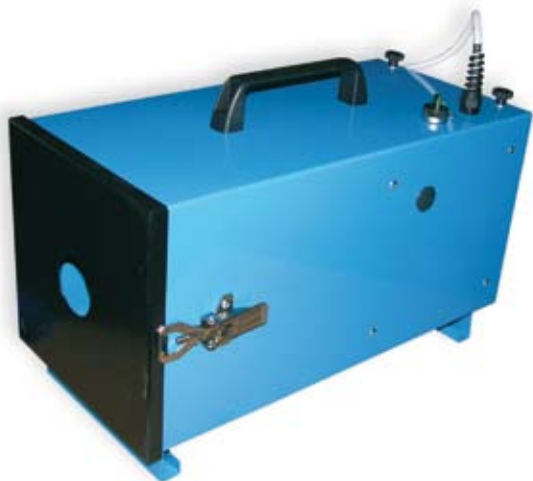

Portable extractor air cleaner with mask, light, hood

MAIN SCOPE:
welding smoke; exhalations and dust

ARTICLE N° **DEPUREX.MINI**

with mechanical cartridge filter

Optionals

Extractor mask with pipe
ø 50 mm length 4000 mm
Circular hood with
magnet ø 100 mm and pipe
ø 50 mm length 3000 mm.
Rectangular hood 300 mm
with magnet
Rectangular hood 600 mm
with magnet
Automatic starting set

Model	N°
MA 50	01
CA 100	01
BA 300	01
BA 600	01
AS	01

Spare parts

Pleated filter cartridge	Filter 104	01
Activated carbon filter	Filter 126	01
Electric fan		01

Components

Polyester filtering cartridge	n°01
End filter in impregnated activated carbon	n°01
Electric fan equipped with brushes	n°01
Extractor sleeve ø 50 mm	n°01
Suction pipe ø 50 mm	L: 1500 mm

Technical characteristics

Filtered air flow	mc/h 200
Filtering system	mechanical cartridge system
Current absorption	w 1100
Head	mm/H ² O 1500
Filtering surface	mq. 1,4
Filter efficiency	99,7 %
Noise	dB 76 (A)
Power supply	V. 230
Connection for extraction/suction	mm 50
Dimensions	D: 300 x L: 530 x H: 300 mm
Weight	Kg. 16

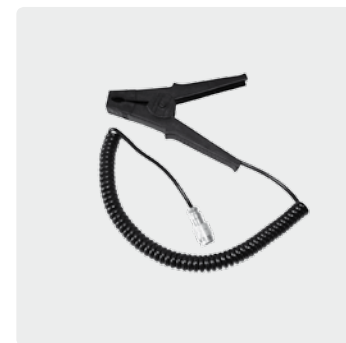
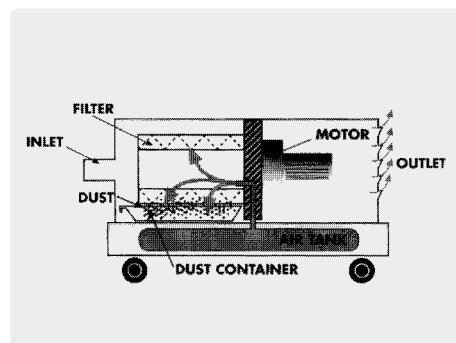

Portable extractor air cleaner with mask, light, hood

MAIN SCOPE:
welding smoke; exhalations and dust

ARTICLE N° **DEPUREX.MINI*AC**

with mechanical cartridge filter and automatic cleaning by means of compressed air

Optionals	Model	N°
Extractor mask with pipe \varnothing 50 mm length 4000 mm	MA 50	01
Circular hood with magnet \varnothing 100 mm and pipe \varnothing 50 mm length 3000 mm	CA 100	01
Rectangular hood 300 mm with magnet	BA 300	01
Rectangular hood 600 mm with magnet	BA 600	01
Spare parts		
Pleated filter cartridge	Filter 106	01
Activated carbon filter	Filter 126	01
Electric fan		01
Pinza partenza automatica	AS	01

Components

Polyester filtering cartridge	n°01
End filter in impregnated activated carbon	n°01
Electric fan equipped with brushes	n°01
Extractor sleeve \varnothing 50 mm	n°01
Suction pipe \varnothing 50 mm	L: 1500 mm
Compressed air 5-litre tank.	n°01

Technical characteristics

Filtered air flow	mc/h 200
Filtering system	mechanical system
Current absorption	w 1100
Head	mm/H ² O 1500
Filtering surface	mq. 1.4
Filter efficiency	99,7 %
Noise	dB 76 (A)
Power supply aria	bar 5
Power supply	V. 230
Connection for extraction/suction	mm 50
Dimensions	D: 450 x L: 530 x H: 550 mm
Weight	Kg.33

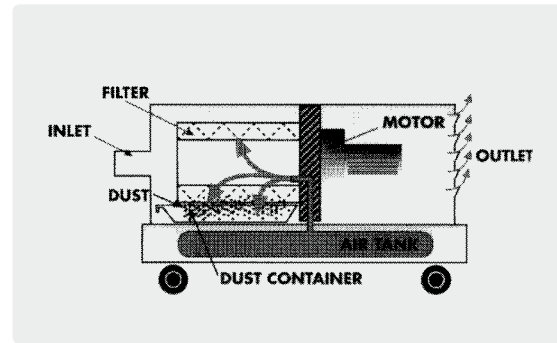

Portable extractor air cleaner with mask, light, hood

MAIN SCOPE:

Welding smoke; exhalations and dust

ARTICLE N° **DEPUREX.MINI*AC/S**

with mechanical cartridge filter, automatic cleaning by means of compressed air

Optionals	Model	N°
Extractor mask with pipe ø 50 mm length 4000 mm	MA 50	01
Circular hood with magnet ø 100 mm and pipe ø 50 mm length 3000 mm	CA 100	01
Rectangular hood 300 mm with magnet	BA 300	01
Rectangular hood 600 mm with magnet	BA 600	01
Spare parts		
Pleated filter cartridge	Filter 106	01
Activated carbon filter	Filter 126	01
Electric fan		01

Components

Polyester filtering cartridge	n°01
End filter in impregnated activated carbon	n°01
Electric fan equipped with brushes	n°01
Extractor sleeve ø 50 mm	n°01
Suction pipe ø 50 mm	L: 1500 mm
Compressed air 5-litre tank.	n°01

Technical characteristics

Filtered air flow	mc/h 200
Filtering system	mechanical system
Current absorption	w 1100
Head	mm/H ₂ O 1500
Filtering surface	mq. 1.4
Filter efficiency	99,7 %
Noise	dB 76 (A)
Power supply aria	bar 5
Power supply	V. 230
Connection for extraction/suction	mm 50
Dimensions	D: 450 x L: 530 x H: 550 mm
Weight	Kg.33



Depuratore portatile per aspirazione con maschere torce e cappe o per macchine utensili

MAIN SCOPE:

welding smoke; oil mist and fumes

ARTICLE N° **DEPUREX.MINI/E**

DEPUREX MINI E

with electrostatic & metal composite filter

Article N° DEPUREX.MINI/E - MINI E/OIL version

with possible additional oil mist preabatement tank

Optionals

	Model	N°
Extractor mask with pipe ø 50 mm length 4000 mm	MA 50	01
Circular hood with magnet ø 100 mm and pipe ø 50 mm length 3000 mm	CA 100	01
Rectangular hood 300 mm with magnet	BA 300	01
Rectangular hood 600 mm with magnet	BA 600	01

Components

Metal prefilter	n°01
Electrostatic cell	n°01
Electric fan	n°01
Extractor sleeve ø 50-120-150 mm	n°01

Technical characteristics

Filtered air flow	mc/h 700 / 200
Filtering system	electrostatic system
Current absorption	w 200 / 1100 W
Head	mm/H ² O 150 / 1500
Filter efficiency	99,7%
Noise	dB 76 (A)
Power supply	V. 230
Connection for extraction/suction	mm 150 - 120 - 50
Dimensions	D: 500 x L: 530 x H: 550 mm
Weight	Kg.53



Trailer-mounted extractor air cleaner with adjustable arm

MAIN SCOPE:
welding smoke; fumes and dry dust

ARTICLE N° **MILLENNIUM**

MILLENNIUM 1.5HP *with mechanic & metal composite filter*

Components

Metal + polyester prefilter	n°01
Semi-absolute filter	n°01
Activated carbon back-up filter	n°01
Electric fan 1.5 HP	n°01
Extractor sleeve ø 200 mm	n°01
Flex 3 extractor arm	n°01

Spare parts

	Model	N°
Semi-absolute filter for Millennium	Filter 200	01
Activated carbon back-up filter for Millennium	Filter 207	01
Metal + polyester prefilter for Millennium	Filter 204	01

Technical characteristics

Filtered air flow	mc/h 1500
Filtering system	mechanical system
Current absorption	w 1100
Head	mm/H ₂ O 140
Filtering surface	m ² . 8,2
Filter efficiency	99,7%
Noise	dB 71 (A)
Power supply	V. 230/380
Connection for extraction/suction	mm 200
Arm length	3 linear metres
Dimensions	D: 720 x L: 700 x H: 900 mm
Weight	Kg.120

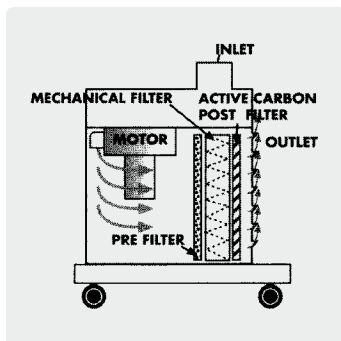

Trailer-mounted extractor air cleaner with adjustable arm

MAIN SCOPE:
welding smoke; fumes and dry dust

ARTICLE N° **DEPUREX.M1**

DEPUREX M1 1.5HP with mechanical metal composite filter

Components

Metal prefilter	n°01
Polyester prefilter	n°01
Semi-absolute filter	n°01
Activated carbon back-up filter	n°01
Electric fan 1.5 HP	n°01
Extractor sleeve ø 200 mm	n°01
Flex 3 extractor arm	n°01
Hour counter (not to be cleared)	n°01

Optionals

	Model	N°
Automatic starting set	AS	01

Spare parts

Metal prefilter	Filter 130	01
Polyester prefilter	Filter 135	01
Activated carbon back-up filter	Filter 140	01
Semi-absolute filter	Filter 143	01

Technical characteristics

Filtered air flow	mc/h 1600
Filtering system	mechanical system
Current absorption	w 1100
Head	mm/H ₂ O 140
Filtering surface	mq. 12,5
Filter efficiency	99,7%
Noise	dB 71 (A)
Power supply	V. 230/380
Arm length	3 linear metres
Connection for extraction/suction	mm 200
Dimensions	D: 780 x L: 780 x H: 900 mm
Weight	Kg. 140

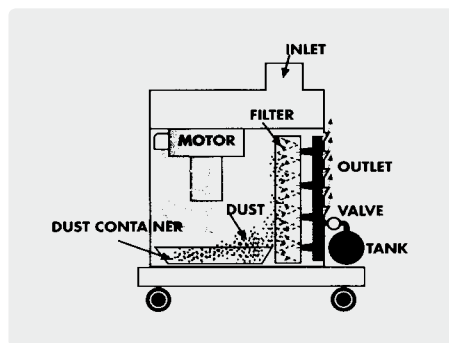

Trailer-mounted extractor air cleaner with adjustable arm

MAIN SCOPE:

welding smoke; dust from grinding, fumes and dry dust

ARTICLE N° **DEPUREX.M1*AC**

DEPUREX M1 AC 1.5HP

*with mechanical metal composite filter;
automatic cleaning by means of compressed air*

Components

Metal prefilter	n°01
Semi-absolute filter	n°01
Polyester prefilter	n°01
Electric fan 1.5 HP	n°01
Extractor sleeve ø 200 mm	n°01
Flex 3 extractor arm	n°01
Hour counter (not to be cleared)	n°01
Compressed air 8-litre tank	n°01
Solenoid valve with timer	n°01

Spare parts

Metal prefilter	Filter 130	01
Polyester prefilter EU7	Filter 112	01
Semi-absolute filter	Filter 116	01

Technical characteristics

Filtered air flow	mc/h 1600
Filtering system	mechanical system
Current absorption	w 1100
Head	mm/H ₂ O 140
Filter efficiency	99,7%
Filtering surface	m ² 12,5
Noise	dB 71 (A)
Power supply	V. 230/380
Power supply aria	Max 5 Bar
Arm length	3 linear metres
Connection for extraction/suction	mm 200
Dimensions	D: 780 x L: 780 x H: 900 mm
Weight	Kg.165

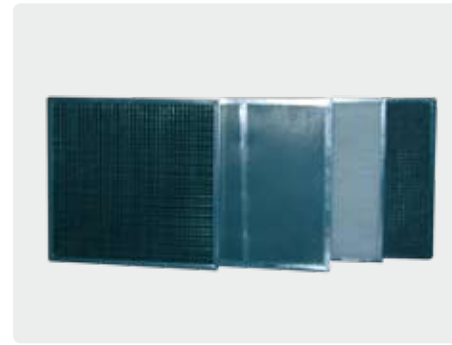

Trailer-mounted extractor air cleaner with adjustable arm

MAIN SCOPE:
welding smoke; solvent and smoke of plastic molding

ARTICLE N° **DEPUREX.M1/CARBON**

DEPUREX M1 CARBON 1.5HP *with mechanical metal composite filter and activated carbon cell*

Components

Metal prefilter	n°01
Polyester prefilter	n°01
Activated carbon filter 15 kgs	n°01
Activated carbon back-up filter	n°01
Electric fan 1.5 HP	n°01
Extractor sleeve ø 200 mm	n°01
Flex 3 extractor arm	n°01
Hour counter (not to be cleared)	n°01

Spare parts

Metal prefilter	Filter 130	01
Polyester prefilter	Filter 135	01
Activated carbon filter 15 kgs	Filter 325	01
Activated carbon back-up filter	Filter 140	01

Technical characteristics

Filtered air flow	mc/h 1600
Filtering system	mechanical system
Current absorption	w 1100
Head	mm/H ₂ O 140
Filter efficiency	99,7%
Noise	dB 71 (A)
Power supply	V. 230/380
Arm length	3 linear metres
Connection for extraction/suction	mm 200
Dimensions	D: 780 x L: 780 x H: 900 mm
Weight	Kg.165

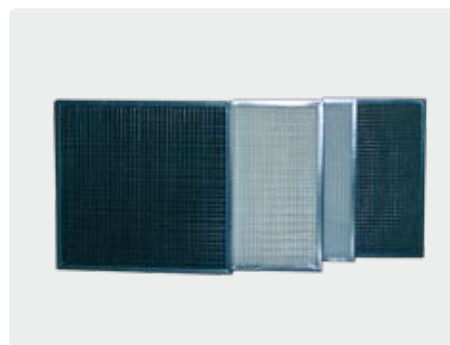

Trailer-mounted extractor air cleaner with adjustable arm

MAIN SCOPE:
welding smoke; fumes and dry dust

ARTICLE N° **DEPUREX.M1/3HP**

DEPUREX M1 3HP *with mechanical metal composite filter*

Components

Metal prefilter	n°01
Semi-absolute filter	n°01
Polyester prefilter	n°01
Activated carbon back-up filter	n°01
Electric fan 3 HP	n°01
Extractor sleeve ø 200 mm	n°01
Flex 3 extractor arm	n°01
Hour counter (not to be cleared)	n°01
Solenoid valve with timer	n°01

Optionals

	Model	N°
Automatic starting set	AS	01

Spare parts

Metal prefilter	Filter 130	01
Polyester prefilter	Filter 135	01
Activated carbon back-up filter	Filter 140	01
Semi-absolute filter	Filter 143	01

Technical characteristics

Filtered air flow	mc/h 1800
Filtering system	mechanical system
Current absorption	w 2200
Head	mm/H ₂ O 160
Filter efficiency	99,7%
Filtering surface	mq. 12,5
Noise	dB 71 (A)
Power supply	V. 230/380
Arm length	3 linear metres
Connection for extraction/suction	mm 200
Dimensions	D: 780 x L: 780 x H: 900 mm
Weight	Kg.165

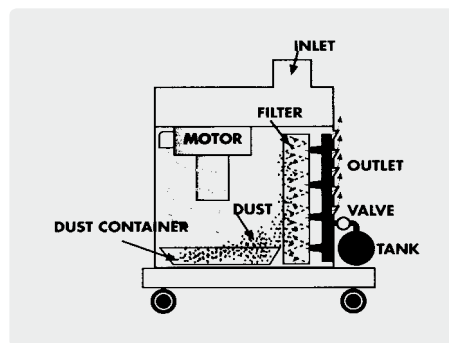

Trailer-mounted extractor air cleaner with adjustable arm

MAIN SCOPE:

Welding smoke; dust from grinding, fumes and dust

ARTICLE N° **DEPUREX.M1*AC/3HP**

DEPUREX M1 AC 3HP

with mechanical filter - automatic cleaning of compressed air

Components

Metal prefilter	n°01
Semi-absolute filter	n°01
Polyester prefilter	n°01
Electric fan 3 HP	n°01
Extractor sleeve ø 200 mm	n°01
Flex 3 extractor arm	n°01
Hour counter (not to be cleared)	n°01
Compressed air 8-litre tank	n°01
Solenoid valve with timer	n°01

Spare parts

Metal prefilter	Filter 130	01
Polyester prefilter EU7	Filter 112	01
Semi-absolute filter	Filter 116	01

Technical characteristics

Filtered air flow	mc/h 1800
Filtering system	mechanical system
Current absorption	w 2200
Head	mm/H ₂ O 160
Filter efficiency	99,7%
Filtering surface	mq. 12,5
Noise	dB 74 (A)
Power supply	V. 230/380
Power supply aria	max. 5 Bar
Arm length	3 linear metres
Connection for extraction/suction	mm 200
Dimensions	D: 780 x L: 780 x H: 900 mm
Weight	Kg. 190

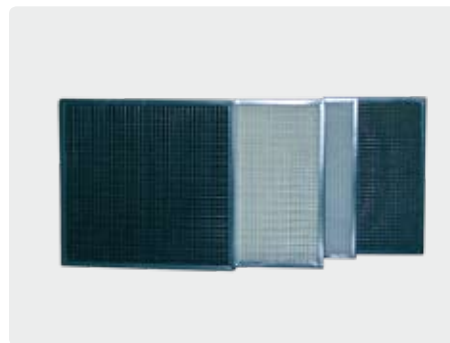

Trailer-mounted extractor air cleaner with 2 adjustable arms

MAIN SCOPE:
welding smoke; fumes and dry dust

ARTICLE N° **DEPUREX.M2**

DEPUREX M2 3HP *with mechanical metal composite filter*

Components

Metal prefilter	n°01
Semi-absolute filter	n°01
Polyester prefilter	n°01
Electric fan 3 HP	n°01
Extractor sleeve ø 200 mm	n°02
Flex 3 extractor arm	n°02
Hour counter (not to be cleared)	n°01
Compressed air 8-litre tank	n°01
Solenoid valve with timer	n°01

Optionals

	Model	N°
Automatic starting set	AS	01

Spare parts

Metal prefilter	Filter 130	01
Polyester prefilter	Filter 135	01
Activated carbon back-up filter	Filter 140	01
Semi-absolute filter	Filter 143	01

Technical characteristics

Filtered air flow	mc/h 2200
Filtering system	mechanical system
Current absorption	w 2200
Head	mm/H ₂ O 140
Filter efficiency	99,7%
Filtering surface	mq. 12,5
Noise	dB 74 (A)
Power supply	V. 230/380
Arm length	3 linear metres
Connection for extraction/suction	mm 200
Dimensions	D: 780 x L: 780 x H: 900 mm
Weight	Kg.210

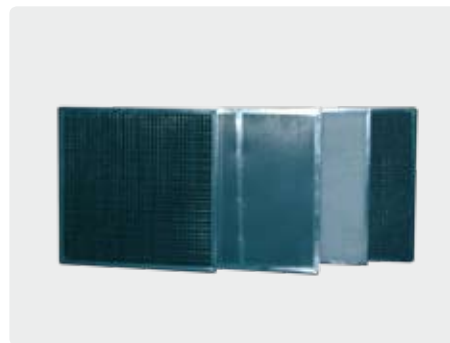

Trailer-mounted extractor air cleaner with adjustable arms

MAIN SCOPE:
*welding smoke; solvent and
smoke of plastic molding*

ARTICLE N° **DEPUREX.M2/CARBON**

DEPUREX M2 CARBON 3HP *with mech. metal composite filter and activated carbon cell*

Components

Metal prefilter	n°01
Filter a carbone attivo	n°01+01
Electric fan 3 HP	n°01
Extractor sleeve ø 200 mm	n°02
Flex 3 extractor arm	n°02
Hour counter (not to be cleared)	n°01

Spare parts

	Model	N°
Metal prefilter	Filter 130	01
Activated carbon filter 15 kgs	Filter 325	01
Filter a carbone attivo 8 KG	Filter 142	01

Technical characteristics

Filtered air flow	mc/h 2200
Filtrating system	mechanical system
Current absorption	w 2200
Head	mm/H ₂ O 140
Filter efficiency	99,7%
Noise	dB 74 (A)
Power supply	V. 230/380
Arm length	3 linear metres
Connection for extraction/suction	mm 200
Dimensions	D: 780 x L: 780 x H: 900 mm
Weight	Kg. 210

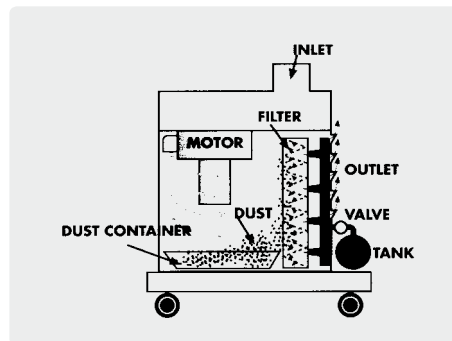

Trailer-mounted extractor air cleaner with 2 adjustable arms

MAIN SCOPE:
welding smoke; dust from grinding, fumes and dry dust

ARTICLE N° **DEPUREX.M2*AC**

DEPUREX M2 AC 3HP with mechanical metal composite filter; automatic cleaning by means of compressed air

Components

Metal prefilter	n°01
Semi-absolute filter	n°01
Polyester prefilter	n°01
Electric fan 3 HP	n°01
Extractor sleeve ø 200 mm	n°02
Flex 3 extractor arm	n°02
Hour counter (not to be cleared)	n°01
Compressed air 8-litre tank	n°01
Solenoid valve with timer	n°01

Spare parts

	Model	N°
Metal prefilter	Filter 130	01
Polyester prefilter EU7	Filter 112	01
Semi-absolute filter	Filter 116	01

Technical characteristics

Filtered air flow	mc/h 2200
Filtering system	mechanical system
Current absorption	w 2200
Head	mm/H ₂ O 140
Filter efficiency	99,7%
Filtering surface	m ² 12,5
Noise	dB 74 (A)
Power supply	V. 230/380
Power supply aria	max. 5 Bar
Arm length	3 linear metres
Connection for extraction/suction	mm 200
Dimensions	D: 780 x L: 780 x H: 900 mm
Weight	Kg.220

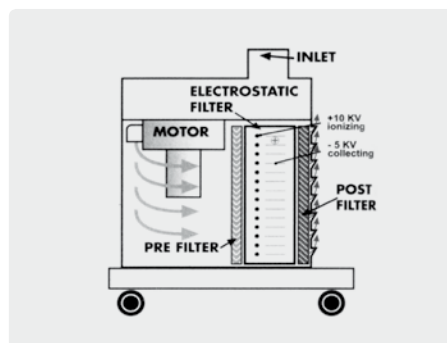

Trailer-mounted extractor air cleaner with adjustable arm

MAIN SCOPE:
welding smoke; fumes and oil mist,
smoke of plastic molding

ARTICLE N° DEPUREX.E1/1.5

DEPUREX E1 1.5HP

with electrostatic and composite filter

Components

Metal prefilter	n°01
Electrostatic cell	n°01
Filter finale composito	n°01
Electric fan 1.5 HP	n°01
Extractor sleeve ø 200 mm	n°01
Flex 3 extractor arm	n°01
Hour counter (not to be cleared)	n°01

Optionals

	Model	N°
Automatic starting set	AS	01

Spare parts

Fine-mesh metal filter	Filter 132	01
Electrostatic cell	Filter NA200	01
End composite prefilter	Filter 116	01

Technical characteristics

Filtered air flow	mc/h 1600
Filtering system	electrostatic system
Current absorption	w 1100
Head	mm/H ₂ O 140
Filter efficiency	99,7%
Filtering surface	mq. 12,5
Noise	dB 74 (A)
Power supply	V. 230/380
Arm length	3 linear metres
Connection for extraction/suction	mm 200
Dimensions	D: 780 x L: 780 x H: 900 mm
Weight	Kg. 165



Trailer-mounted extractor air cleaner with 2 adjustable arms

MAIN SCOPE:
welding smoke; fumes and dry dust,
smoke of plastic molding

ARTICLE N° **DEPUREX.E2**

DEPUREX E2 1.5HP with electrostatic and composite filter

Components

Metal prefilter	n°01
Electrostatic cell	n°01
Filter finale composito	n°01
Electric fan 1.5 HP	n°01
Extractor sleeve ø 200 mm	n°02
Flex 3 extractor arm	n°02
Hour counter (not to be cleared)	n°01

Optionals

	Model	N°
Automatic starting set	AS	01

Spare parts

Fine-mesh metal filter	Filter 132	01
End composite prefilter	Filter 116	01
Electrostatic cell	Filter NA200	01

Technical characteristics

Filtered air flow	mc/h 2000
Filtering system	electrostatic system
Current absorption	w 1100
Head	mm/H ² O 120
Filter efficiency	99,7%
Filtering surface	m ² . 12,5
Noise	dB 71 (A)
Power supply	V. 230/380
Arm length	3 linear metres
Connection for extraction/suction	mm 200
Dimensions	D: 780 x L: 780 x H: 900 mm
Weight	Kg. 210



FLEX mobile extractor arms

MAIN SCOPE:

*Localized dust collection
and fume extraction FLEX 300*

ARTICLE N° **DEPUREX.FLEX300**

FLEX 300

Technical characteristics

Connection for extraction/suction	mm 200
Arm length	3 linear metres
Bracket dimensions	D: 300 x L: 750 x H: 240 mm
Weight	Kg. 33

ARTICLE N° **DEPUREX.FLEX400**

FLEX 400

Technical characteristics

Connection for extraction/suction	mm 200
Arm length	ml 4
Bracket dimensions	D: 300 x L: 750 x H: 240 mm
Weight	Kg. 33

Optionals

Extension for extractor arm 1-metre length, complete with bracket
 Extension for extractor arm 2-metre length, complete with bracket
 Extension for extractor arm 3-metre length, complete with bracket

Model

P1
 P2
 P3

N°

01
 01
 01



FLEX mobile extractor arms with electric fan

MAIN SCOPE:

Localized dust collection and fume extraction

ARTICLE N° **DEPUREX.FLEX300/2**

ARTICLE N° **DEPUREX.FLEX400/2**

FLEX 300 2 HP

Technical characteristics

Filtered air flow	mc/h 1500
Electric fan	HP 2
Current absorption	w 1500
Head	180 mm/H ² O
Noise	dB 71 (A)
Connection for extraction/suction	mm 200
Arm length	3 linear metres
Bracket dimensions	D: 300 x L: 750 x H: 240 mm
Weight	Kg. 63

FLEX 400 2 HP

Technical characteristics

Filtered air flow	mc/h 1500
Electric fan	HP 2
Current absorption	w 1500
Head	180 mm/H ² O
Noise	dB 71 (A)
Connection for extraction/suction	mm 200
Arm length	ml 4
Bracket dimensions	D: 300 x L: 750 x H: 240 mm
Weight	Kg. 66

Optionals

Extension for extractor arm 1-metre length, complete with bracket
 Extension for extractor arm 2-metre length, complete with bracket
 Extension for extractor arm 3-metre length, complete with bracket

Model

P1
 P2
 P3

N°

01
 01
 01

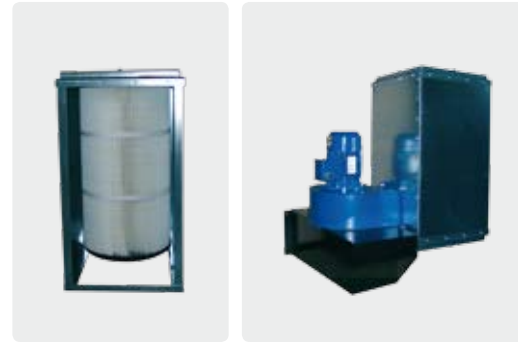

FLEX mobile extractor arms with electric fan and mechanical filter

MAIN SCOPE:

Localized dust collection and fume extraction

ARTICLE N° **DEPUREX.FLEX300/2M**

FLEX 300 M 2 HP

With pleated PE cartridge filter

Technical characteristics

Filtered air flow	mc/h 1500
Electric fan	HP 2
Current absorption	w 1500
Head	180 mm/H ² O
Noise	dB 71 (A)
Connection for extraction/suction	mm 200
Filtering surface	mq. 12
Arm length	3 linear metres
Filter efficiency	99,7 %
Bracket dimensions	D: 300 x L: 750 x H: 240 mm
Weight	Kg. 90

Optionals

Extension for extractor arm 1-metre length, complete with bracket
Extension for extractor arm 2-metre length, complete with bracket
Extension for extractor arm 3-metre length, complete with bracket

ARTICLE N° **DEPUREX.FLEX400/2M**

FLEX 400 M 2 HP

With pleated PE cartridge filter

Technical characteristics

Filtered air flow	mc/h 1500
Electric fan	HP 2
Current absorption	w 1500
Head	180 mm/H ² O
Noise	dB 71 (A)
Connection for extraction/suction	mm 200
Filtering surface	mq. 12
Arm length	ml 4
Filter efficiency	99,7 %
Bracket dimensions	D: 300 x L: 750 x H: 240 mm
Weight	Kg. 100

Model

P1	N° 01
P2	01
P3	01

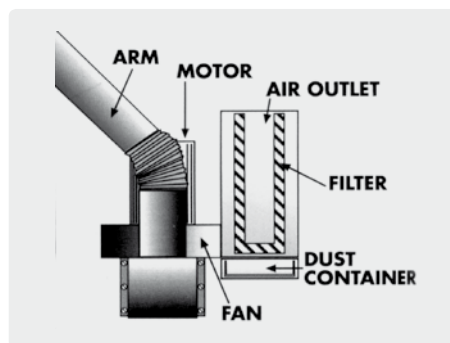

FLEX mobile extractor arms with electric fan and automatic-cleaning filter

MAIN SCOPE:

Localized dust collection and fume extraction

ARTICLE N° **DEPUREX.FLEX300/2AC**

FLEX 300 AC 2 HP

*With pleated PE cartridge filter
cleaning by means of compressed air*

Technical characteristics

Filtered air flow	mc/h 1500
Electric fan	HP 2
Current absorption	w 1500
Head	180 mm/H ² O
Noise	dB 71 (A)
Connection for extraction/suction	mm 200
Filtering surface	mq. 12
Arm length	3 linear metres
Filter efficiency	99,7 %
Bracket dimensions	D: 300 x L: 750 x H: 240 mm
Weight	Kg. 100
Serbatoio aria	lt. 5 + elettrovalvola temp.

Optionals

	Model	N°
Extension for extractor arm 1-metre length, complete with bracket	P1	01
Extension for extractor arm 2-metre length, complete with bracket	P2	01

ARTICLE N° **DEPUREX.FLEX400/2AC**

FLEX 400 AC 2 HP

*With pleated PE cartridge filter
cleaning by means of compressed air*

Technical characteristics

Filtered air flow	mc/h 1500
Electric fan	HP 2
Current absorption	w 1500
Head	180 mm/H ² O
Noise	dB 71 (A)
Connection for extraction/suction	mm 200
Filtering surface	mq. 12
Arm length	ml 4
Filter efficiency	99,7 %
Bracket dimensions	D: 300 x L: 750 x H: 240 mm
Weight	Kg. 115
Serbatoio aria	lt. 5 + elettrovalvola temp.

continuo Optionals

	Model	N°
Extension for extractor arm 3-metre length, complete with bracket	P3	01

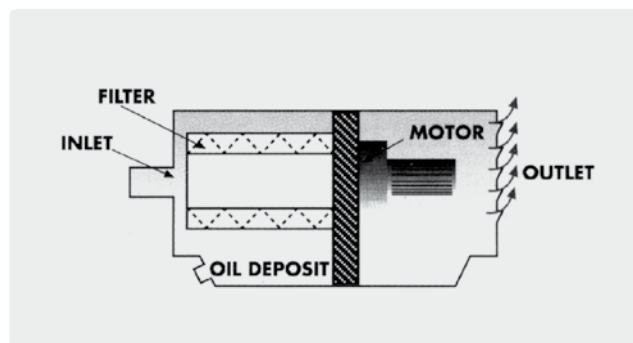

Portable air cleaners For oil mist extraction

MAIN SCOPE:
Oil mist & fume extraction

ARTICLE N° **DEPUREX.OIL/S**

DEPUREX OIL 1.5 HP with mechanical filter equipped with oil-repellent cartridge - metal composite filters

Optionals

Circular hood with magnet
ø 250 mm and pipe
ø 150 mm length 3000 mm
4-wheel set (2 wheels are
equipped with brake)

Model N°

CA 150 01

R80 01

Spare parts

Metal cartridge filter for OIL	Filter 160	01
Semi-absolute back-up filter	Filter 225	01
Polyester + carbon filter	Filter 235	01

Components

Cartuccia filtrante oleorepellente metallica	n°01
Semi-absolute filter	n°01
Filter poliestere e carbone	n°01
Electric fan 1.5 HP	n°01
Extractor sleeve ø 150 mm	n°01

Technical characteristics

Filtered air flow	mc/h 1200
Filtering system	mechanical system
Current absorption	w 1100
Head	mm/H ² O 150
Filtering surface	mq. 5
Filter efficiency	99,9 %
Noise	dB 71 (A)
Power supply	V. 230/380
Connection for extraction/suction	mm 150
Dimensions	D: 500 x L: 700 x H: 500 mm
Weight	Kg. 65



Trailer-mounted air cleaner to suck shavings and dust

MAIN SCOPE:

*cleaning in workshops, shaving collection
from tool machines, joiner's shops etc.*

ARTICLE N° **ELEPHANT/3HP**

ELEPHANT *with Teflon bag filter*

Components

Teflon bag filter	n°01
Electric blower 3 hp	n°01
Extractor sleeve ø 50 mm	n°01
Extraction piping ø 50 mm length 5000 mm	n°01
Dust suction opening	n°01

Technical characteristics

Filtered air flow	mc/h 600
Filtering system	mechanical system
Current absorption	w 2200
Head	mm/H ² O 2250
Filtering surface	mq. 0.5
Filter efficiency	97 %
Noise	dB 71 (A)
Power supply	V. 230/380
Connection for extraction/suction	mm 50
Dimensions	D: 770 x L: 870 x H: 1500 mm
Weight	Kg. 235



Trailer-mounted dust sucking device to suck dry dust and dust from grinding operations

MAIN SCOPE:

Dust from grinding operations and dry dust

ARTICLE N° **DEPUREX.TWISTER**

TWISTER

with mechanical composite filter

Mod. HP 3

RPM 2850 g/l
Noise db (A) 73
Capacity 1300 mc/h
Head 310 mm H²O

Mod. HP 5.5

RPM 2900 g/l
Noise db (A) 77
Capacity 2400 mc/h
Head 380 mm H²O

Mod. HP 4

RPM 2850 g/l
Noise db (A) 77
Capacity 1500 mc/h
Head 350 mm H²O

Mod. HP 7.5

RPM 2900 g/l
Noise db (A) 82
Capacity 3000 mc/h
Head 430 mm H²O

Technical characteristics

Filtering system	mechanical system metallico comp.
Flex hose length ø 150/Flex Arm	4 mtrs / 3-4 mtrs
Connection for extraction/suction	mm 150
Power supply	380 V trifase
Filtering surface	mq. 12,5
Filter efficiency	99,7 %
Dimensions	D: 720 x L: 1200 x H: 900 mm
Weight	Kg. 265

Spare parts

	Model	N°
PreFilter metallico	Filter 130	01
PreFilter in polistere	Filter 135	01
Activated carbon back-up filter	Filter 140	01
Semi-absolute filter	Filter 143	01

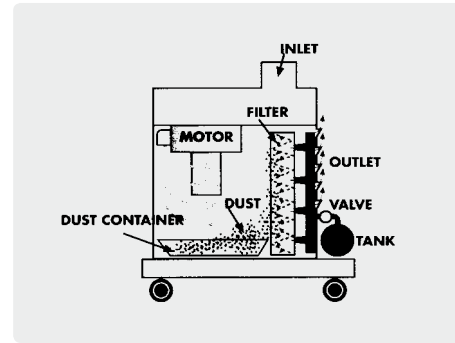

Trailer-mounted cleaner
To suck dust from grinding operations
cleaning by means of compressed air

MAIN SCOPE:
Dry dust and dust from grinding operations

ARTICLE N° **DEPUREX.TWISTER/AC**

TWISTER / AC

with mechanical composite filter and
cleaning by means of compressed air

Mod. HP 3

RPM 2850 g/l
 Noise db (A) 73
 Capacity 1300 mc/h
 Head 310 mm H²O

Mod. HP 5.5

RPM 2900 g/l
 Noise db (A) 77
 Capacity 2400 mc/h
 Head 380 mm H²O

Mod. HP 4

RPM 2850 g/l
 Noise db (A) 77
 Capacity 1500 mc/h
 Head 350 mm H²O

Mod. HP 7.5

RPM 2900 g/l
 Noise db (A) 82
 Capacity 3000 mc/h
 Head 430 mm H²O

Technical characteristics

Filtering system	mechanical system metallico + composito
Flex hose length ø 150/Flex Arm	4 mtrs / 3-4 mtrs
Connection for extraction/suction	mm 150 / 200
Power supply	380 V trifase
Power supply aria	max 5 Bar
Filtering surface	mq. 12,5
Filter efficiency	99,7 %
Compressed air 8-litre tank	n°01
Solenoid valve with timer	n°01
Dimensions	D: 720 x L: 1200 x H: 900 mm
Weight	Kg. 265

Spare parts

	Model	N°
PreFilter metallico	Filter 130	01
Polyester prefilter EU7	Filter 112	01
Composite end back-up filter	Filter 116	01

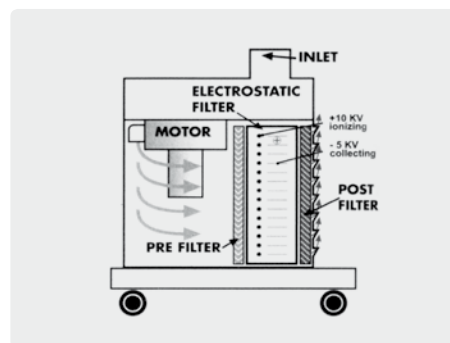

Trailer-mounted extractor bench

MAIN SCOPE:

welding smoke and any kind of fumes

ARTICLE N° **DEPUREX.TABLE.E**

TABLE KIT E 1.5 HP

with electrostatic & composite filters

Components

Metal prefilter	n°01
Electrostatic cell	n°01
PostFilter composito	n°01
Electric fan 1.5 HP	n°01
Hour counter (not to be cleared)	n°01

Technical characteristics

Filtered air flow	mc/h 1800
Filtering system	electrostatic system
Current absorption	w 1100
Head	mm/H ² O 140
Filter efficiency	99,7 %
Noise	dB 71 (A)
Power supply	V 230 /380
Working surface dimensions	L: 1080 x D: 730 mm
Dimensions	D: 780 x L: 1080 x H: 680 mm
Weight	Kg. 230

Optionals

	Model	N°
Automatic starting set	AS	01

Spare parts

Metal prefilter	Filter 132	01
Electrostatic cell	Filter NA200	01
Composite end back-up filter	Filter 116	01



Trailer-mounted extractor bench

MAIN SCOPE:

welding smoke and any kind of fumes

ARTICLE N° **DEPUREX.TABLE.M**

TABLE KIT M 3HP

with electrostatic & composite filters

Optionals

Automatic starting set

Model

AS

N°

01

Spare parts

Metal prefilter
Polyester prefilter
Filter semi assoluto
Activated carbon back-up filter

Filter 130	01
Filter 135	01
Filter 143	01
Filter 140	01

Components

Metal prefilter	n°01
Polyester prefilter	n°01
Semi-absolute filter	n°01
Activated carbon back-up filter	n°01
Electric fan 3 HP	n°01
Hour counter (not to be cleared)	n°01

Technical characteristics

Filtered air flow	mc/h 2200
Filtering system	mechanical system
Current absorption	w 2200
Head	mm/H ₂ O 140
Superficie filtrante	mq. 12,5
Filter efficiency	99,7 %
Noise	dB 74 (A)
Power supply	V 230 /380
Working surface dimensions	L: 1080 x D: 730 mm
Dimensions	D: 780 x L: 1080 x H: 680 mm
Weight	Kg. 230



Modular extractor bench **With mechanical & composite filtering**

MAIN SCOPE:

these benches are planned and produced according to customer's needs

ARTICLE N° LAATS1 – LAATS2 - LAATS

ATS

with metal & composite filters

Mod. ATS 1

Width	1000
Depth	900
Surface height	840
HP power	3
Air flow mc/h	4000
Filtering surface	6,6

Mod. ATS 2

Width	2000
Depth	900
Surface height	840
HP power	5,5
Air flow mc/h	8000
Filtering surface	13,2

Mod. ATS 3

Width	3000
Depth	900
Surface height	840
HP power	7,5
Air flow mc/h	11000
Filtering surface	19,8

Technical characteristics

these benches are made of sturdy shaped sheet and are equipped with dust collection chests, on their lower side. The working surface has extracting holes, supporting profiles as well as extractable panels for maintenance purposes. Both front and side-walls can be extracted. A metal filter is mounted inside the bench. Two versions of this article are available: either with metal filter or with filtering hose battery and automatic cleaning by means of electric vibrator



***Modular extractor cabs sucking dust from grinding operations and extracting welding smoke
Mechanical filtering by means of suction hoses and automatic cleaning***

AVAILABLE MODELS

IDRO CM 2 extractor cab sucking dust from grinding operations and extracting welding smoke
Technical characteristics: dimensions 2000 x 2000 x 1500 H mm
extraction capacity 4500,00 mc/ h
current absorption 3 kW

IDRO CM 3 extractor cab sucking dust from grinding operations and extracting welding smoke
Technical characteristics: dimensions 2000 x 3000 x 1500 H mm
Extraction capacity 6500,00 mc/ h
current absorption 4 kW

IDRO CM 4 extractor cab to suck dust from grinding operations and extract welding smoke
Technical characteristics: dimensions 2000 x 4000 x 1500 H mm
Extraction capacity 9000,00 mc/ h
current absorption 5.5 kW

Technical characteristics

IDRO CM extractor cabs sucking dust from grinding operations and extracting welding smoke.
Technical characteristics:
solid structure made of hot-galvanized 20/10 sheet with reinforcement tubular elements
extracting dust collection panels being placed in front of the working place and also on its sides
non-sparking metal prefilters
filtering battery with suction hoses - automatic cleaning system with electromechanical shaker
highly effective dust collection electric fan with reverse blades



Centralized welding smoke extracting plants with mechanical filtering by means of hoses and/or pockets



Technical characteristics

Centralized plants extracting fumes, oil mist and sucking dust from metal polishing, grinding and sandblasting, thermal cutting, foundries, solvent abatement etc.

Technical characteristics:

solid circular canalization made of

hot-galvanized 8/10 sheet with bearing brackets

exhalation extracting systems equipped

with condensate abatement devices and/or extractor hoods

filtering battery equipped with pockets and/or hoses - automatic

cleaning by means of electromechanical shaker or compressed air

highly effective dust collection electric fan with reverse blades



I nostri Agenti esclusivi

Lombardia

Ercole Mancinelli
Agente esclusivo Lombardia
Cell. 348.7673633
e.mancinelli@libero.it

Veneto / Friuli / Trentino

F.LLI BOTTACIN
Via Germania, 15
Z.I. Camin – Padova
Tel. 049.8705928
Fax 049.7629768
Sig. Gianluca 348.4417354

Toscana e Umbria

DAMAR sas di Marchisio Marco & C.
Via XXV Aprile, 15
50032 Borgo San Lorenzo (FI)
tel. 055.8458072 – 055.8456832
Sig. Marco 335.6595264
Sig. Andrea 348.3413752

Campania

RUSSO GIANPAOLO
Via Spirito Santo, 55
80049 SOMMA VESUVIANA (NA)
Tel./Fax 081/8994384
Cell. 348.3026420



IDRODEPUREX IMPIANTI s.r.l.

Via del Commercio, 9 - 46010 Curtatone (MN)

Tel. 0376.348368 - Fax 0376.348047

info@idrodepureximpianti.com

www.idrodepureximpianti.com